

TECHNICAL BULLETIN

Serck Audco Super-H

Pressure Balanced Taper Plug Valve



Contents

Super-H Design	3
Super-H Features Explained.....	4
Why Select a Plug Valve?.....	5
Why Select a Super-H?	5
Range	6
Materials.....	7
Sample Applications.....	8
Figure Numbering.....	10
Standards and Quality Assurance	11
Pressure Testing.....	12
Super-H Operation.....	13
Accessories	14
Valve Data.....	15
Sealants.....	36
Sealants Injection Equipment.....	38
Sealants Packaging	38
Serck Audco Stem Packing Compound.....	38
The Products of Success.....	39

Super-H Design

Super-H is the pressure balanced Plug Valve that Serck Audco has developed while leading the market over the last 90 years. With the most typical applications found in natural gas, upstream hydrocarbon and slurries, this well-established design has proven its suitability on a range of demanding applications when zero leakage or bubble tight shut-off and reliability of operation are of prime importance.

Basic design advantages such as metal-to-metal seats and a wide seating area, along with competitive pricing, have made plug valves the product of choice when the valve is operated in a difficult or dirty service and/or needs to be opened against full differential pressure. The robust metal-to-metal seats ensure long valve life on any service, even in presence of solid particles in the line media.

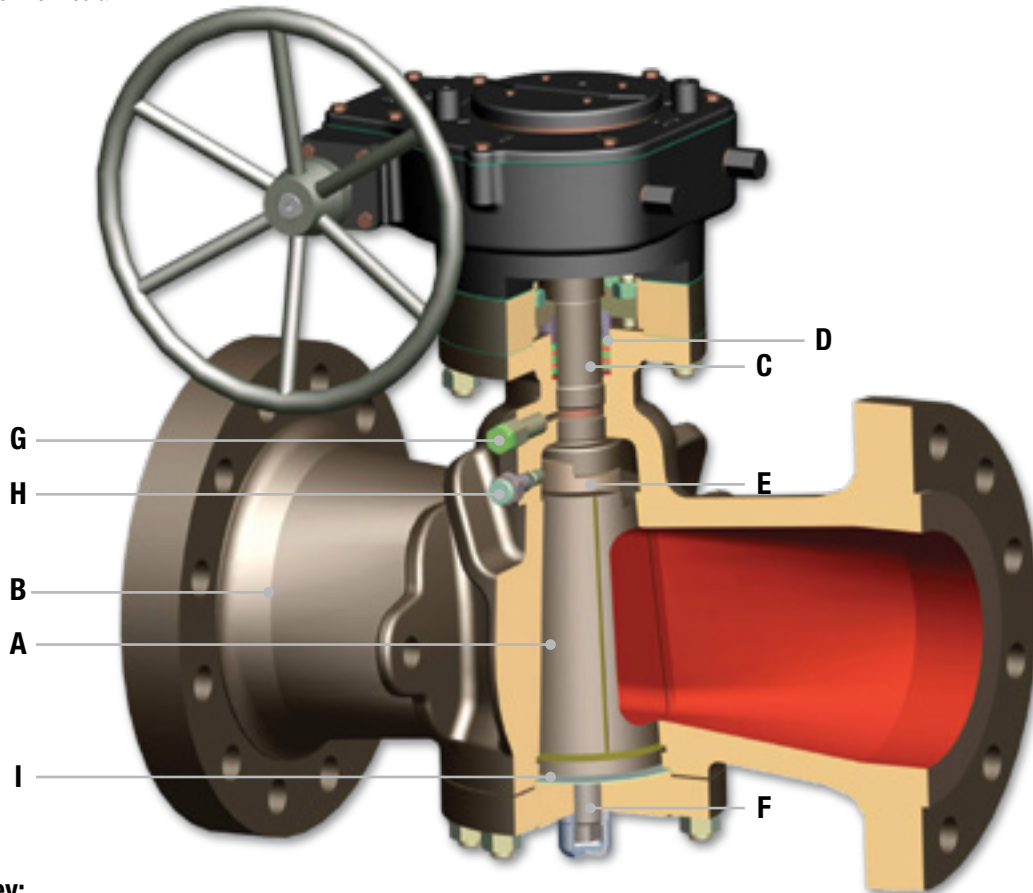

Key:

A	Plug – Metal-to-metal wide seating area with Super LoMu Treatment for low torque
B	Body – Simple and robust design with no cavities
C	Stem – Anti blow out with Super LoMu Treatment
D	Gland – Adjustable with fugitive emission proof graphite packing
E	Equalizer ring – Prevents side loads for efficient stem to-plug connection

F	Plug Loading Screw – Factory set to ensure seat tightness with low torque
G	Stem Packing Injector – Renews stem packing and allows full in-line maintenance
H	Sealant Injector – Maintains bubble tight shut-off for the life of the valve
I	Cover Seals – Metal for long life and increased fire safety

Super-H Features Explained

Plug Balancing

All Super-H valves are protected against the possibility of seizure due to taper locking.

Taper locking is a phenomenon common to conventional type plug valves, caused by an imbalance of forces acting on the plug due to line pressure finding its way into the chamber at the larger end of the plug. As shown by the arrows in Fig. 1, the resultant force tends to push the plug into the taper, potentially jamming it in its tapered bore. The plug can remain locked even when line pressure is subsequently reduced.

In an attempt to combat taper locking, conventional plug valves utilise the pressure of the plug sealant, acting on the upper face of the plug, to react against the upwards force. This required frequent sealant injection maintains a smooth valve operation.

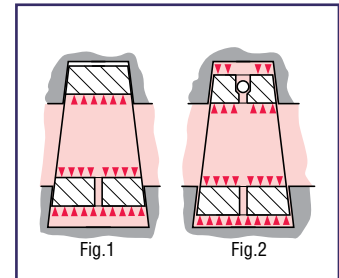

Pressure Balancing

Super-H valves incorporate pressure balanced plugs as standard, as shown in Fig. 2. The passages top and bottom with a check valve at the smaller end of the plug allow the line pressure itself to balance the forces acting on the plug, preventing any possibility of taper locking – thus maintaining trouble-free operation without the need for frequent sealant injection.

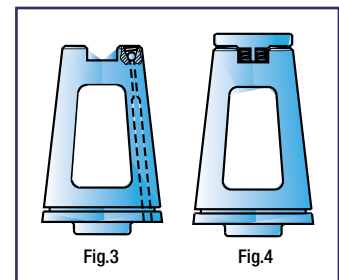

Protected Pressure Balancing

For increased reliability in service where there is a possibility of foreign particles in the media, we can incorporate as an option, the protected pressure balance system (Fig. 3). This design ensures that the balancing holes are not exposed to the line media in the plug port, providing added security compared with normal pressure balancing.

Plug Balancing Spring

This design (Fig. 4) preloads the plug to prevent taper locking during pressure and/or temperature transients. Available as an option, this also enables total flexibility in piping configuration, regardless of valve orientation.



Super LoMu®

Super LoMu is our proprietary PTFE based anti-friction treatment. All Super-H plugs and stems are Super LoMu treated to ensure our valves have the lowest possible torques over the longest possible lifetime.

Super LoMu is a treatment of the metal surface that reduces coefficient of friction while maintaining a true metal-to-metal contact, and we can apply it to every material combination.

Super LoMu has extreme durability, as can be seen in the photograph illustrating the difference after 20,000 cycles between a conventional anti-friction treatment, compared with our Super LoMu treatment.



Fire Safety

Super-H Valves are designed to perform well when subjected to a fire, not only a standard defined fire but also the varying temperatures and durations likely in a real plant fire. The Super-H design is inherently fire-safe as it is free from plastic materials or elastomers. The plug seats are metal-to-metal, the cover seal is metal-to-metal or graphite and the stem seal is graphite. Additionally, Super LoMu will ensure operability even after exposure to fire test conditions. Super-H has been fire tested and will meet all published fire test standards worldwide, including ISO 10497 and API 6FA.



Emission Control

Industry standards are tightening the requirements on emissions levels permitted from pressurized equipment. Super-H valves are ahead of the game and are designed and tested to meet the most stringent fugitive emission requirements. Our adjustable gland design, combined with high performance graphite stem packing materials, ensures low emissions over extensive temperature and mechanical cycling, even without the use of O-rings or PTFE seals.

Why Select a Plug Valve?

Robust **metal-to-metal seats** cope well with the solid impurities that can run at high velocities in close proximity to the integral seating surfaces, particularly when the valve is opened against a high differential pressure. Plug valves are the preferred choice for bypass and equalisation on main gas pipelines by most major gas transportation companies. (Fig. 5)

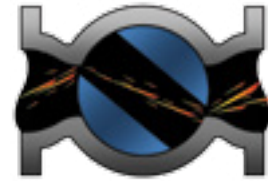

Fig.5

Robust metal-to-metal seats have also high resistance to solids objects and **lack of gap/cavity** between plug and body ensure that particles do not become trapped between plug and body thus avoiding damage to the seats while closing the valve. (Fig. 6)



Fig.6

Large seating area further enhances the Super-H resistance to erosion. The wide area maximizes the effectiveness of sealant, so that if the valve starts passing it can quickly be solved by injecting Serck Audco Sealant, restoring the valve's **bubble tight shut-off** capabilities without the need of valve overhaul. Sealant can be injected with the valve in any position and also under pressure, making the valve **in-line maintainable**. (Fig. 7)



Fig.7

When the valve is open, unlike in other valve designs, the **seats are well protected** from the line media. This ensures that even if the valve is left open for long periods of time, its seating areas will not get damaged, thus ensuring good sealing and **long valve life**. (Fig. 8)



Fig.8

Why Select a Super-H?

With experience in valves manufacturing dating back to 1869 and a continuous drive for improvement, Serck Audco has all the knowledge to make the finest quality plug valve, including:

Benefit	How It Is Achieved
<ul style="list-style-type: none"> • Certainty of zero leakage sealing down the line, even with damaged metal seats 	<ul style="list-style-type: none"> • Precise seat mating procedures • Effective sealant injection system combined with wide seating areas
<ul style="list-style-type: none"> • Certainty of operation with low and consistent torque which is stable over long periods of time • Minimal maintenance regime 	<ul style="list-style-type: none"> • Pressure balanced plug as standard, with option of Protected Pressure balance® • Super LoMu Anti Friction Treatment on plug and stem • Precise factory set plug loading
<ul style="list-style-type: none"> • Full in-line maintainability even under full pressure and without any need of shut down 	<ul style="list-style-type: none"> • Provision for sealant injection for the seats • Provision for stem packing re-injection
<ul style="list-style-type: none"> • Assured sealing to atmosphere 	<ul style="list-style-type: none"> • Independent stem sealing design that can meet stringent fugitive emissions requirements • All pressure seals in fire safe metal or graphite

Range

Super-H valves are available in Regular, Short or Venturi Pattern, in accordance with API 6D, API 599 and BS 5353. The different patterns vary in regard to face-to-face dimension and port area for a given size of valve.

- Regular Pattern valves have the largest port area and the same face-to-face dimension as ball valves.
- Short Pattern valves have a reduced port area as a consequence of their compact face-to-face dimensions, which match those of gate valves, and are used on low pressure classes.
- Venturi Pattern valves have a reduced port area and a flow path approximating a Venturi shape to aid pressure recovery. They tend to be used in larger size valves.

Face-to-face and end-to-end dimensions conform to ANSI B16.10 and BS 2080.

The table shows our current production range with a coloured indication of the usually selected patterns. For many size/pressure class combinations, more than one pattern is available as indicated in the cells.

Serck Audco can make special configurations/sizes/classes and our actual range is wider than shown below, so for valves not shown in the table please contact Serck Audco with specific requirements.

API 6D Dimensions	in	1/2	3/4	1	1.1/2	2	3	4	6	8	10	12	14	16	18	20	24	26	28	30	36	42	
	mm	15	20	25	40	50	80	100	150	200	250	300	350	400	450	500	600	650	700	750	900	1050	
PN20 - ANSI 150	S/R	S/R	S/R	S/R	S/R	S/R	S/R	S/R	S/R	S/R	S/R	S/R/V	V	V	V	V	V	V	V	V	V	V	V
PN50 - ANSI 300	S/R	S/R	S/R	S/R	S/R	S/R	S/R	S/R	R/V	R/V	R/V	R/V	V	V	V	V	V	V	V	V	V	V	V
PN100 - ANSI 600	R	R	R	R	R	R	R	R	R/V	R/V	R/V	R/V	R/V	R/V	R/V	R/V	V	V	V	V	V	V	V
PN150 - ANSI 900	R	R	R	R	R	R	R	R	R	R	R/V	R/V	V	V	V	V	V	V	V	V	V	V	V
PN250 - ANSI 1500	R	R	R	R	R	R	R	R	R	R/V	R/V	R/V	V	V	V	V	V	V	V	V	V	V	V
PN420 - ANSI 2500	R	R	R	R	R	R	R	R	R	R	R	R											
API 2000						•	•	•	•														
API 3000						•	•	•	•														
API 5000						•	•	•	•														
API 10000						•	•	•	•														
API 6A Dimensions	in					2.1/16	3.1/8	4.1/16	7.1/16														
	mm					52	78	103	179														

Most Common Pattern:

Short

Regular

Venturi

API 6A

Refer to individual cells for all available patterns

Serck Audco Valves also manufactures the Super-H pressure balanced Plug Valve in special configurations such as:

Full Bore



Three Way



Twin Isolation



Double Isolation



Steam Jacketed

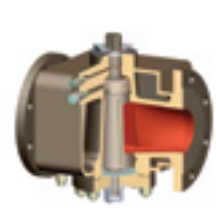

Other particular configurations can be considered upon request to suit particular application

Materials

Serck Audco Valves has extensive experience in manufacturing our Super-H in a wide range of materials to comply with any particular application or project specification. Below are few samples of the most common material combinations:

Service	Body / Cover	Plug	Stem / Eq Ring	Cover Bolting
Sweet Natural Gas and most non-aggressive services	Carbon Steel ASTM A216 WCB/WCC	ASTM A216WCB/WCC + Case Hardening	Alloy Steel ASTM A322 4140	ASTM A193 B7 + ASTM A194 2H (B7M/2HM if NACE bolting is required)
Sour Services (ISO 15156 – NACE)		ASTM A216WCB/WCC + ENP		
Abrasive Services		17-4PH Martensitic Stainless Steel	17-4PH Martensitic Stainless Steel	
API 6A	60K Carbon Steel ASTM A487 Gr 4	ASTM A747 Gr. Cb7Cu1	ASTM A564 Ty 630	
Low Temperature Services	Low Temp. Carbon Steel ASTM A352 LCB/LCC	ASTM A352 LCB/LCC + ENP	ASTM A322 4140	ASTM 320 L7 + ASTM A194 7
Corrosive Services	Austenitic Stainless Steel ASTM A351 CF3M/CF8M	ASTM A351 CF3M/CF8M + ENP	ASTM A564 Ty 630	ASTM A193 B8M + ASTM A194 8M
Corrosive and Abrasive Services	Duplex / Super Duplex Stainless Steel ASTM A995 4A/5A	ASTM A995 4A/5A + ENP	ASTM A182 F51/F55	UNS S32760
Highly Corrosive Services	ASTM A216 WCB/WCC + Inconel 625 Overlay	ASTM A216 WCB/WCC + Inconel 625 Overlay + ENP	Inconel 718	ASTM A193 B7 + ASTM A194 2H
Highly Abrasive Services	ASTM A216 WCB/WCC + Stellite Hard Facing	ASTM A216 WCB/WCC + Stellite Hard Facing	ASTM A322 4140	

Notes: Other Material combinations are available

Super LoMu Anti Friction Treatment (AFT) is always applied on plugs and stem to reduce friction

For small or flat parts, equivalent forged or plate grade is also widely used in lieu of castings

Super-H for Special Abrasive and Corrosive Services

Super-H plug valves are ideally suited to applications where the line media is abrasive or corrosive, even with standard materials. For very aggressive services, the internal surfaces of the valves can be hard faced or overlaid with a selection of alloys specially identified and tested by Serck Audco Valves. The choice of materials and surface treatments depends on the nature of the service. Hard facing and overlay can be applied to internal parts in four levels of increasing coverage:

- On the seating surfaces of plug and body only
- On the all surface of the body and plug tapers
- On the all surface of the body and plug tapers plus the body and plug flow bore
- On all wetted parts

The result is superior technical performance and dramatically extended valve life at an affordable cost.

We recommend that customers consider hard facing or overlay for severe applications, such as: sand entrained oil and gas production, water injection, high temperature catalyst conveying, slurry handling and transportation etc.

For very highly abrasive services, hard faced valves are also available in full bore construction.



Sample Applications

Super-H Plug Valves should be selected whenever bubble tight shut-off (zero leakage) is needed and there is a concern about seat damage due to valves being opened against a full differential pressure and/or the presence of solids or impurities in the process medium.



High Pressure Gas Isolation

Bubble tight shut-off on one of the more searching medias

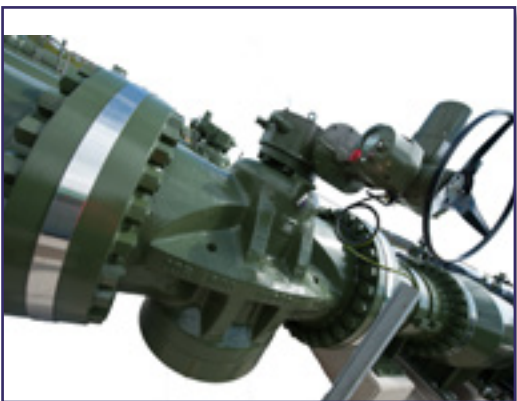

Kicker, Vent and Drain on Scraper Traps

Tight shut-off combined with limited throttling capabilities



Slurry Isolation

Extremely abrasive services, a robust valve with no cavities

Sample Applications

Bypass Equalizing Valves

To resist the erosion caused by full differential pressure openings on a transmission line, it will seal to protect the main line valve



Underground Storage

Protected metal seating to resist impurities and give zero leakage even on the highest pressures



Flowline Manifold Isolation

Isolation ensured on high pressure dirty service



Figure Numbering

A familiarity with our figure numbering system is not necessary when specifying or ordering our valves. Providing a full description of the valve is given, our sales office will translate this into a figure number. A full description of the valve begins with 'Super-H Pressure Balanced Valve', and gives size, pressure rating, flanging details, materials of construction, application and every customer datasheet or specification available.

We give an example below with the most common coding in order to illustrate a typical figure number:

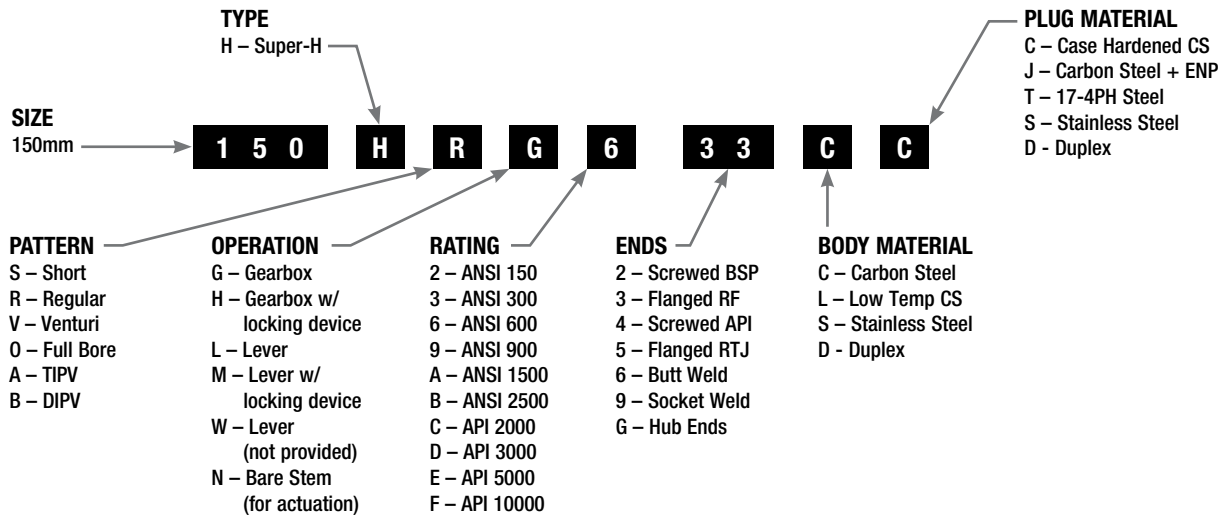

Super Duplex Super-H with Hub Ends is a typical requirement on offshore oil production platforms, and is preferred to other valves due to its compact and lightweight form and resistance to foreign particles.



Standards and Quality Assurance

Super-H valves meet the requirements of API 6D, API 599, BS5353 and ANSI B16.34 as standard. Valves to meet API 6A are also available. Typical industry standards that we are often asked to comply with are listed in the below table. Other standards can be considered against specific request.

API 6D (ISO 14313)	Specification for pipeline valves
API 6A (ISO 10423)	Specification for wellhead equipment
API 599	Metal plug valves – flanged, threaded and welding ends
BS 5353	Specification for steel plug valves
ASME B16.34	Valves – flanged, threaded and welding end
BS EN14141	Valves for natural gas transportation in pipelines. Performance requirements and tests
ISO 15848-1/2	Industrial valves. Measurement, test and qualification procedures for fugitive emissions
ASME B16.10	Face-to-face and end-to-end dimensions of valves
BS EN 12627 BS EN 558 (formerly BS 2080)	Face-to-face, center-to-face, end-to-end, and center-to-end dimensions of flanged and butt welding end steel valves for the petroleum, petrochemical and allied industries
ASME B16.5	Pipe flanges and flanged fittings
BS EN 12266-1 BS EN 12266-2 API 598	Industrial valves. Testing of valves. Pressure tests, test procedures and acceptance criteria.
ISO 10497	Testing of valves. Fire type-testing requirements
API 6FA	Specification for fire test for valves
BS EN ISO 15156 (formerly NACE MR0175)	Sulphide stress cracking resistant metallic material for oilfield equipment
BS EN ISO 9001	Quality assurance approval standard
97/23/EC	Pressure equipment directive

The Search for Quality

The name Serck Audco Valves is synonymous with quality assured products throughout the petrochemical and process industries. This reputation has been achieved over the years by careful attention to all aspects of quality control and assurance.

The entire manufacturing process follows procedures as laid down in the Flowserve Company Quality Assurance Manual. Regular systems audits by third parties, our own QA department and customer assessments ensure these procedures are regularly revised and updated. The manual complies with BS EN ISO 9001 and API Q1 (ISO TS 29001).

Quality Assurance, Inspection and Testing

With Super-H, quality is present at every stage to ensure that the range is manufactured to a consistently high standard. All suppliers are assessed to ensure they meet our rigorous standards. Goods Received Inspection maintains performance records and vendor ratings. By using the latest technology such as CNC machining and CMM inspection, the machining accuracy on the Super-H product range is outstanding. Stringent control of all processes including hard facing and Super LoMu Treatment ensures a uniformly high-quality, low-friction product. All manufacturing and assembly processes are monitored to ensure the product is right the first time with trouble-free installation, commissioning and a very long life.

Exhaustive testing at component and final product stages ensure that every valve meets the required performance levels. The Customer Inspection Department handles all materials witnessed by the customer or third party inspectors. All tests are substantiated as a minimum by EN 10204 3.1 certificates on pressure tests, NDTs and pressure containing parts mechanical and chemical tests.

Pressure Testing

All Super-H valves are hydrostatically tested on body and seats at the following pressures before dispatch:

Valve Rating	Maximum C.W.P.		Body Test		Seat Test	
	Bar	Psi	Bar	Psi	Bar	Psi
PN20 - ANSI 150	19.5	285	29.3	427.5	21.5	313.5
PN50 - ANSI 300	51.1	740	76.7	1110	56.3	814
PN100 - ANSI 600	102.1	1480	153.2	2220	112.4	1628
ANSI 800	138	2000	207	3000	151.8	2200
PN150 - ANSI 900	153.2	2220	229.8	3330	168.6	2442
PN250 - ANSI 1500	255.3	3705	383	5558	280.9	4075.5
PN420 - ANSI 2500	425.5	6170	638.3	9255	468.1	6787
API 2000	138	2000	276	4000	138	2000
API 3000	207	3000	414	6000	207	3000
API 5000	345	5000	517	7500	345	5000
API 10000	690	10000	1035	15000	690	10000

(Class 800 pressures are taken from BS 5353, API pressures are taken from API 6A, all other pressures are taken from ANSI 16.34. The test pressures from ASME B16.34 are those relevant to Carbon Steel ASTM A216 Gr.WCB)

Even though API6D generally allows a seat leakage rate while testing metal seated valves, it shall be noted that for lubricated plug valves (such as the Super-H) in accordance with API6D no seat leakage is allowed (ISO 5208 class A).

Each relevant standard defines the minimum length of time for which each test pressure is to be maintained and also the testing operations sequence, Super-H valves are tested as a minimum to API 6D, whose test durations are longer than API 598 and BS EN 12266-1

Valve Size		API 6D	
Mm	In	Shell Test (min)	Seat Test (min)
≤ 50	≤ 2	2	2
65 – 100	2 ½ - 4	2	2
150	6	5	5
200 – 250	8 – 80	5	5
300	12	15	5
350 – 450	14 – 18	15	5
≥ 500	≥ 20	30	5

Other test durations can be accommodated to satisfy a particular order specification, optional special tests are also available such as

- Low pressure air test
- High pressure gas test
- Fugitive emission testing
- Low and high temperature testing



3 1/16" API 10,000 Super-H

Super-H Operation

The pressure balance and Super-LoMu features ensure that a Super-H valve always turns with the lowest possible effort

Torque Figures

All Super-H valves manual operating mechanisms are sized to allow valve operation with a maximum effort of 350N, a gearbox is always fitted when this effort cannot be obtained by using a lever.

Figures given in the table are the maximum turning efforts at the valve stem that will occur while opening the valve against full differential pressure. The figures quoted are based on actual test data and have been chosen to give a good approximation to a normally expected operating maximum torque, with the inclusion of an adequate safety factor.

Be aware that torque figures may change between different patterns or materials of construction. Line pressure has a direct effect on turning effort - for example if the line pressure is reduced to zero, the torque at the stem will be approximately 75% of the figures shown for full differential pressure. There are many other factors which influence the valve torque, including the operating regime of the valve and the extent of any erosive or corrosive damage.

Always refer to Serck Audco Valve to know the exact torque figure of the valve supplied.

SIZE		150			300			600		900		1500		2500
mm	in	SHT	REG	VEN	SHT	REG	VEN	REG	VEN	REG	VEN	REG	VEN	REG
40	1.½	95	95		95	95		170		212		272		694
50	2	95	95		95	95		190		367		462		694
80	3	163	163		231	231		340		476		714		976
100	4	238	238		340	340		680		707		748		2400
150	6	299	612			612	424	1088	680	1265		1591		2598
200	8	646	1000			1220	612	2040	1088	2149		3400	3400	5195
250	10	1020	1900			1999	1224	2715	2040	3801	3801	4700	4700	5195
300	12	1496	2448	2448		2448	1909	4080	2992	5501	3979	5698	5698	8990
350	14			2584			3808	4420	4080		6800		5698	
400	16			2584			3808	7004	4420		6800		10159	
450	18			2720			4200	7602	6038		8622			
500	20			3951			5440	10200	7190		12039		11404	
600	24			4012			6000		9799		12702		18999	

Above Values are in Nm, to convert to lbf multiply by 0.738

Actuators

Due to the quarter-turn nature of the valve design, Super-H valves can easily be actuated by all the industry quarter-turn actuators, including electric, pneumatic, hydraulic, electro hydraulic etc. Serck Audco has years of experience with all major actuator manufacturers. We are happy to include your choice of actuator when manufacturing our valves. Alternatively, we source actuators to your specifications from leading actuator manufacturers around the world. Our plant has the facility to test most common types of actuators while mounted on the valve; giving peace of mind for the complete assembly. When sizing an actuator, a further safety factor of at least 30% is always added to the expected operating torque figures to allow for variations in working conditions.

When selecting a valve actuator, any actuator sizing should be checked with Serck Audco Valves.



Accessories

Extension Columns

Valves for below ground operation are available with elevated gear unit mounting as shown. Extension can be made with the spindle length required to bring operator to surface. Extension columns in other configurations are available on request. Please contact Serck Audco Valves for more information.

Valve Stands



Valve stands for heavier valves when required to comply with installation procedures are available as an option.

Limit Switches

We can include limit switches on all types of valves for both visual and electronic indication of the valve position. Please specify your requirements when ordering.

Special Gearboxes

Special gearboxes can be provided, these can have different orientation drives for valves installed in difficult locations such as underground pits.

Locking Devices

Locking and interlocking devices are available as option for all Super-H valves. They enable the gearbox or lever to be locked in either the OPEN or SHUT position. Please specify if these are required when ordering.

Other Accessories

Serck Audco is used to handling specific requirements and we are flexible to accommodate non-standard demands. Please contact Serck Audco for more information.

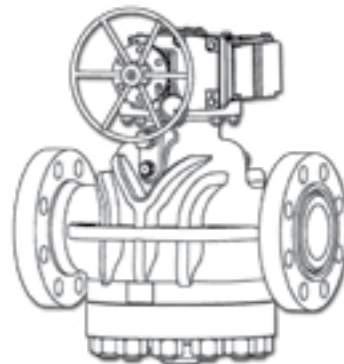
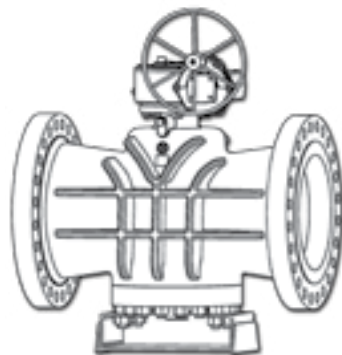

CLASS 150 SHORT PATTERN

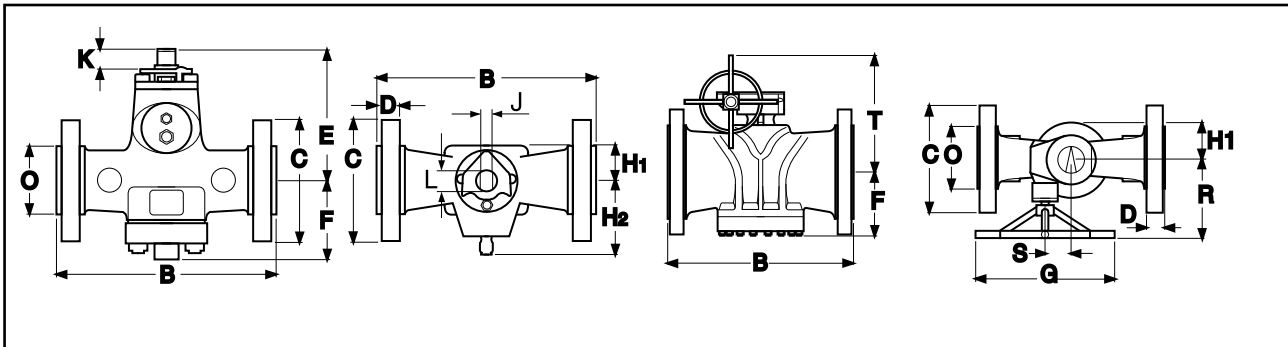

		50 (2")	80 (3")	100 (4")	150 (6")	200 (8")	250 (10")	300 (12")
B	Face-to-face RF	178	203	229	267	292	330	356
C	Flange diameter	153	191	229	280	343	407	483
D	Total flange thickness RF	16	19	24	25.4	28.5	30.5	32
E	CL to top of stem	158	195	205	250	390	457	420
F	CL to bottom of body/cap	121	161	179	209	225	255	282
G	Hand wheel diameter	--	--	--	--	600	700	600
H1	Body width from CL	58	84	93	105	120	130	145
H2	Body width from CL	111	120	134	134	--	--	--
J	Stem Across Flats	19	25.3	25.3	28.5	--	--	--
K	Depth of flats without stop plate	25	26	26	34	--	--	--
K	Depth of flats without stop plate	32	34	34	42	--	--	--
L	Stem diameter	27	35	35	41			
O	Raised face diameter RF	92	127	157.2	216	270	324	381
R	CL to face of hand wheel	--	--	--	--	390	461	390
S	CL valve to CL operating spindle	--	--	--	--	105	148	105
T	CL to top of hand wheel	--	--	--	--	625	715	655
U	CL to end of fitted wrench	494	684	684	933	--	--	--
	Weight (approx) kg	19	33	52	80	162	245	350
	Wrench Number	B4	B5S	B5S	B7	--	--	--

HSL233
Flanged Class 150RF
50-150mm (2-6")

HSG233
Flanged Class 150RF
150-300mm (6-12")

CLASS 150 REGULAR PATTERN

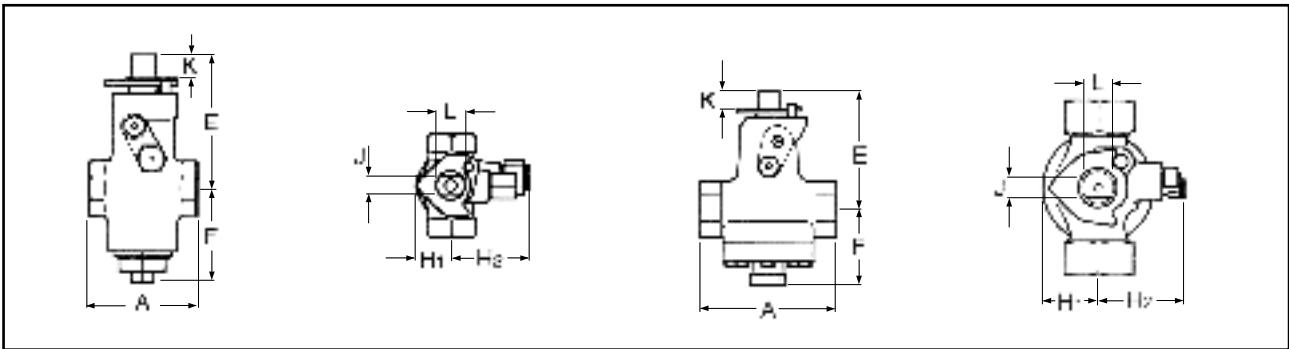

		15 (1/2")	20 (3/4")	25 (1")	40 (1 1/2")	50 (2")
A	End-to-end Screwed / SWE	89	133	133	229	229
E	CL to top of stem	120	127	154	154	174
F	CL to bottom of body/ cap	76	97	97	110	133
H1	Body width from CL	31	36	42	57	72.5
H2	Body width from CL	68	76	76	106	106
J	Stem across flats	13	17	17	19	25.3
K	Depth of flats with stop plate	18	24	24	26	26
K	Depth of flats without stop plate	25	30	30	35	35
L	Stem diameter	19	22.2	22.2	35	35
U	CL to end of fitted wrench	230	318	318	685	685
Z	ID socket	21.7	27.5	34.1	49	61.2
ZA	Depth of socket	10	13	13	13	16
	Weight (approx) kg	2.5	6.8	6.8	22	24.5
	Wrench number	B8	B9	B9	B5S	B5S

HRL222
Screwed BSP Tpr
15-50mm (1/2-2")

HRL244
Screwed API
15-50mm (1/2-2")

HRL299
Socket Weld End
15-50mm (1/2-2")

CLASS 150 REGULAR PATTERN

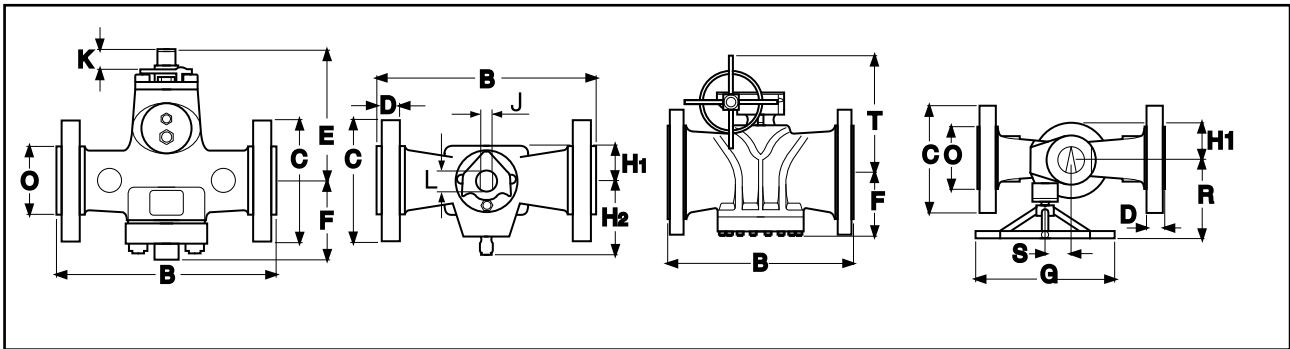

		50 (2")	80 (3")	100 (4")	150 (6")	200 (8")	250 (10")	300 (12")
B	Face-to-face RF	203	241	305	394	457	533	610
C	Flange diameter	153	191	229	280	343	407	483
D	Total flange thickness RF	16	19	24	25.4	28.5	30.5	32
E	CL to top of stem	158	195	205	258	365	485	544
F	CL to bottom of body/cap	121	166	185	191	295	285	405
G	Hand wheel diameter	--	--	--	--	600	700	700
H1	Body width from CL	58	85	93	105	150	145	178
H2	Body width from CL	100	120	133	133	--	--	--
J	Stem across flats	19	25.3	25.3	28.6	--	--	--
K	Depth of flats without stop plate	25	26	26	34	--	--	--
K	Depth of flats without stop plate	32	34	34	42	--	--	--
L	Stem diameter	27	35	35	41			
O	Raised face diameter RF	92	127	157	216	270	324	381
R	CL to face of hand wheel	--	--	--	--	390	461	461
S	CL valve to CL operating spindle	--	--	--	--	105	148	148
T	CL to top of hand wheel	--	--	--	--	590	760	820
U	CL to end of fitted wrench	494	684	684	933	--	--	--
	Weight (approx) kg	22	38	60	92	225	282	415
	Wrench Number	B4	B5S	B5S	B7	--	--	--

HRL233
Flanged Class 150RF
50-150mm (2-6")

HRG233
Flanged Class 150RF
150-300mm (6-12")

CLASS 150 VENTURI PATTERN

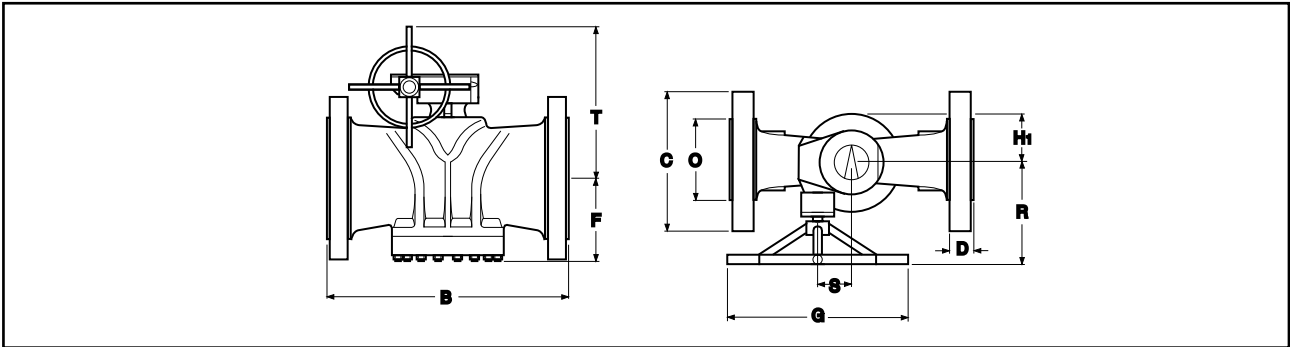

		250 (10")	300 (12")	350 (14")	400 (16")	450 (18")	500 (20")	600 (24")	750 (30")	900 (36")
B	Face-to-face RF	533	610	686	762	864	914	1067	1295	1524
C	Flange diameter	406	483	534	597	635	698.5	813	985	1168.4
D	Total flange thickness RF	30.2	31.8	35.1	36.5	39.6	42.9	48	75	90.5
F	CL to bottom of body/cap	282	403	400	392	395	497.5	485.5	672	897
G	Hand wheel diameter	700	700	700	500	800	700	650	650	762
H1	Body width from CL	148	178	214	214	239	270	264	400	508
O	Raised face diameter RJ	324	381	413	470	533	584	693	857	1022
R	CL to face of hand wheel	422	422	545	501	564	557	580	620	631
S	CL valve to CL operating spindle	148	148	57.5	138	63	26	29	215	235
T	CL to top of hand wheel	738	837	800	672	833	898.5	868	1141	1132
	Weight (approx) kg	280	415	560	630	900	1160	1270	4015	Refer to SAV

HVG233
Flanged Class 150RF
250-900mm (10-36")

CLASS 300 SHORT PATTERN

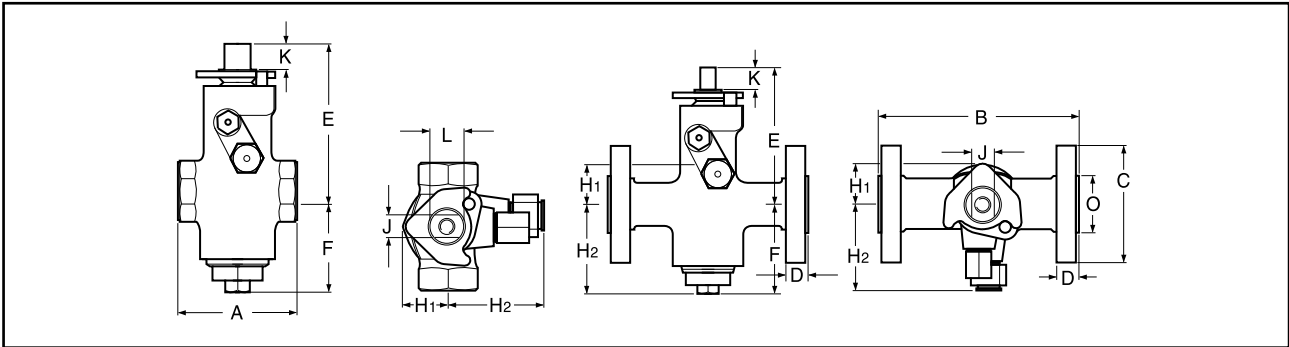

	15 (1/2")	20 (3/4")	25 (1 1/2")	40 (1.1/2")	50 (2")	80 (3")	100 (4")		
A	End-to-end screwed &SWE	89	133	133	228			HSL333 Flanged Class 300RF 40-100mm (1 1/2-4")	
B	Face-to-face RF	139.7	152.4	158.8	190	216	283	305	HSL322 Screwed BSP Tpr 15-40mm (1/2-1 1/2")
C	Flange diameter	95.5	117.5	124	156	165	210	254	
D	Total flange thickness RF	14.2	15.8	17.5	20.6	22.2	28.6	31.8	HSL344 Screwed API 15-40mm (1/2- 1 1/2")
E	CL to top of stem	105	127	127	150	160	194	210	
F	CL to bottom of body/cap	76	97	97	105	125	153	110	
H1	Body width from CL	29	41.5	41.5	57	58	85	93	
H2	Body width from CL	70	80	80	100	110	120	134	HSL399 Socket Weld End 15-40mm (1/2-1 1/2")
J	Stem across flats	13	17	17	19	19	25.3	25.3	
K	Depth of flats with stop plate	19	24	24	25	25	26	26	
K	Depth of flats without stop plate	24	29	29	32	32	34	34	
L	Stem diameter	19	22.2	22.2	27	27	35	35	
O	Raised face diameter RF	35	42.9	50.8	73.2	92	127	157	
U	CL to end of fitted wrench	230	318	318	494	494	684	684	
Z	ID of socket SWE	21.7	27.4	34.1	49				
ZA	Depth of socket SWE	10	13	13	13				
	Weight (approx) kg	2.5(SC/SW) 5.3(FL)	6.8(SC/SW) 9.0(FL)	6.8(SC/SW) 10(FL)	22(SC/SW) 19.5(FL)	24	45	64	
	Wrench number	B8	B9	B9	B4	B4	B5S	B5S	

CLASS 300 REGULAR PATTERN

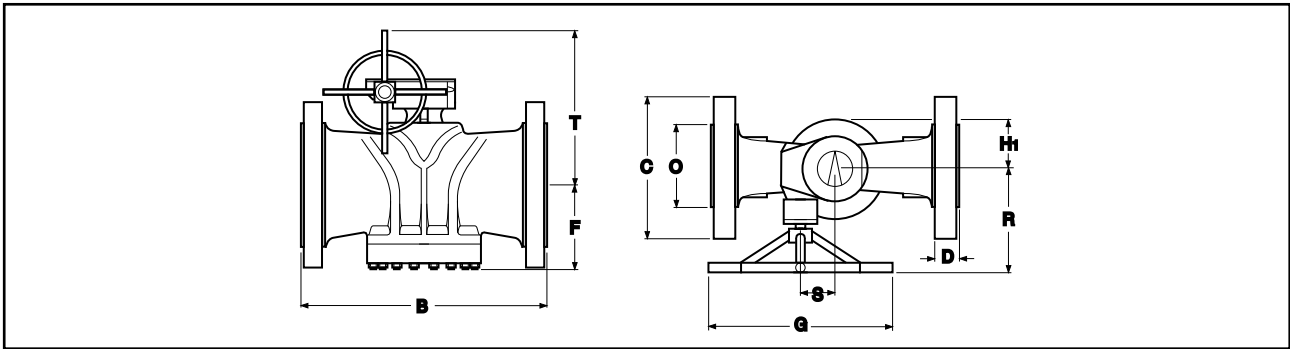

		150 (6")	200 (8")	250 (10")	300 (12")
B	Face-to-face RF	403	502	568.5	711.2
C	Flange diameter	318	381	445	521
D	Total flange thickness RF	36.5	41.1	47.8	50.8
F	CL to bottom of body/cap	240	260	340	370
G	Hand wheel diameter	600	600	700	787
H1	Body width from CL	115	146.5	178	191
O	Raised face diameter RF	216	270	324	381
R	CL to face of hand wheel	390	422	461	575
S	CL valve to CL operating spindle	105	148	148	195
T	CL to top of hand wheel	580	640	770	850
	Weight (approx) kg	150	262	385	550

HRG333
Flanged Class 300RF
150-300mm (6-12")

CLASS 300 VENTURI PATTERN

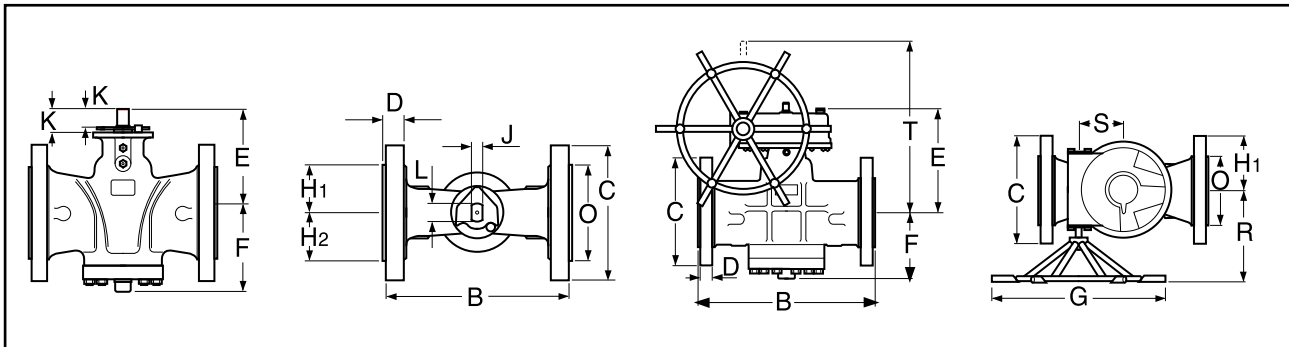

		150 (6")	150 (6")	200 (8")	250 (10")	300 (12")
B	Face-to-face RF	403	403	419.1	457	502
C	Flange diameter	318	318	381	444	521
D	Total flange thickness RF	36.5	36.5	41.1	47.6	50.8
E	CL to top of stem	238	304	335	450	495
F	CL to bottom of body/cap	177	180	210	300	330
G	Hand wheel diameter		600	600	600	700
H1	Body width from CL	85	85	115	145	189
H2	Body width from CL	131.8	-	-	-	-
J	Stem across flats	25.32	-	-	-	-
K	Depth of flats with stop plate	42	-	-	-	-
K	Depth of flats without stop plate	34	-	-	-	-
L	Stem diameter	41	-	-	-	-
O	Raised face diameter RF	216	216	270	324	381
R	CL to face of hand wheel		390	390	425	461
S	CL valve to CL of operator spindle		104.8	104.8	148	148
T	CL to top of hand wheel		540	570	680	770
U	CL to end of fitted wrench	933	-	-	-	-
	Weight (approx) kg	101	121	192	305	508
	Wrench number	B7	-	-	-	-

HVL333
Flanged Class 300RF
150mm (6")

HVG333
Flanged Class 300RF
150-300mm (6"-12")

CLASS 300 VENTURI PATTERN

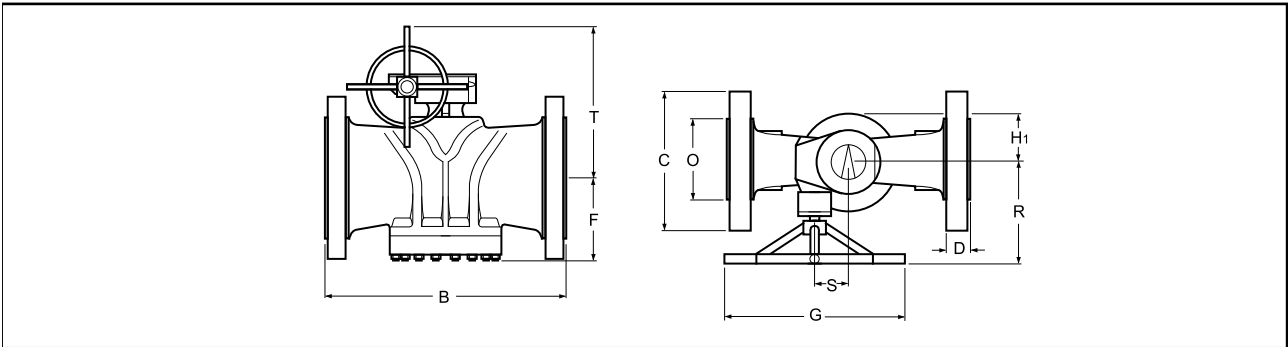

		350 (14")	400 (16")	450 (18")	500 (20")	600 (24")	750 (30")	900 (36")
B	Face-to-face RF	762	838	914	991	1143	1397	1727
C	Flange diameter	584	648	711	775	914	1092	1270
D	Total flange thickness RF	54.1	57.2	60.3	63.5	70	92	104.6
F	CL to bottom of body/cap	395	400	415	520	500	672	837
G	Hand wheel diameter	787	775	775	700	700	700	610
H1	Body width from CL	230	215	243	270	265	400	498
O	Raised face diameter RF	413	470	533	584	692	857	1022
R	CL to face of hand wheel	690	542	557	381	581	620	652
S	CL valve to CL of operator spindle	22.7	63	25.5	51	51	215	305
T	CL to top of hand wheel	835	825	900	915	895	1166	1305
	Weight (approx) kg	750	902	1097	1525	2060	Refer to SAV	9000

HVG333
Flanged Class 300RF
350-900mm (14-36")

CLASS 600 REGULAR PATTERN

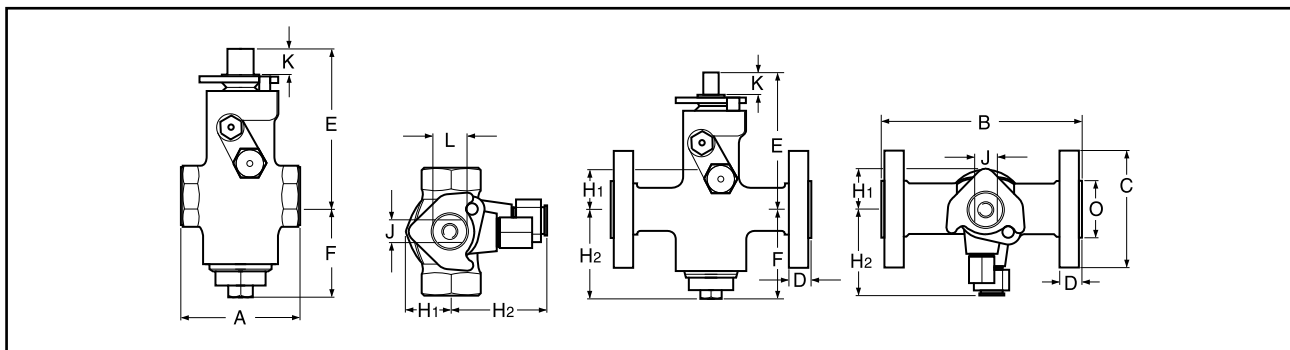

		15 (1/2")	20 (3/4")	25 (1")	40 (1 1/2")	40 (1 1/2")	50 (2")	50 (2")
A	End-to-end screwed &SWE	89	133	133	228	-	229	-
B	End-to-end butt weld valves	-	-	-	-	-	292	-
B	face-to-face RF	165.1	190.5	216	-	241.3	-	292
B	Face-to-face RJ	163.5	190.5	216	-	241.3	-	295
C	Flange diameter	95.5	117.5	124	-	156	-	165
D	Total flange thickness RF	20.7	22.2	23.9	-	29.4	-	31.8
D	Total flange thickness RJ	19.8	22.2	23.9	-	29.4	-	33.32
E	CL to top of stem	120	127	140	135	135	-	175
F	CL to bottom of body/cap	90	97	97	105	105	-	121.5
H1	Body width from CL	29	41.5	41.5	57	57	56	86.5
H2	Body width from CL	86.5	76	76	105	104	105	110.8
J	Stem across flats	13	17	17	19	19	19	19
K	Depth of flats with stop plate	19	24	24	25	25	25	25
K	Depth of flats without stop plate	24	29	29	32	32	32	32
L	Stem diameter	19	22.2	22.2	27	27	27	27
O	Raised face diameter RF	35	42.9	50.8	73.2	73.2	92	92
O	Raised face diameter RJ	50.8	63.5	69.8	90.4	90.4	108	108
U	CL to end of fitted wrench	230	318	318	494	494	495	495
Z	ID of socket SWE	21.7	27,4	34,1	49	-	61.2	-
ZA	Depth of socket SWE	10	13	13	13	-	16	-
	Weight (approx) kg	2.5(SC/SW) 5.3(FL)	6.8(SC/SW) 9.0(FL)	6.8(SC/SW) 10(FL)	22(SC/SW)	19.5(FL)	24.5(SC) 21(BW)	21.3(FL)
	Wrench Number	B8	B9	B9	B4	B4	B4	B4

HRL622
Screwed BSP Tpr
15-50mm (1/2-2")

HRL633
Flanged Class 600RF
15-50mm (1/2-2")

HRL644
Screwed API
15-50mm (1/2-2")

HRL655
Flanged Class 600RJ
15-50mm (1/2-2")

HRL666
Butt Weld End
50mm (2")

HRL699
Socket Weld End
15-50mm (1/2-2")

CLASS 600 REGULAR PATTERN

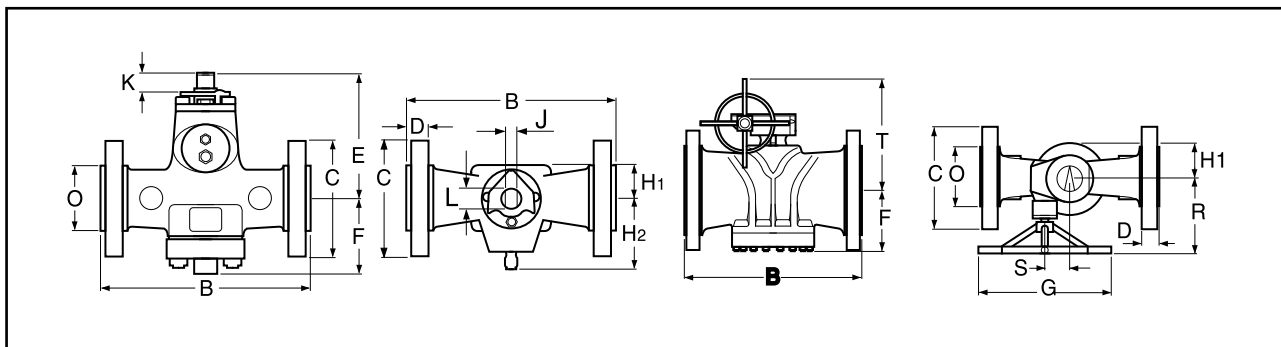

	80 (3")	100 (4")	150 (6")	200 (8")	250 (10")	300 (12")	
B	End-to-end butt weld valves	356	432	559	660	787	838
B	Face-to-face RF	356	432	559	660	787	838
B	Face-to-face RJ	359	435	562	663.5	791	841
C	Flange diameter	210	273	356	419	508	559
D	Total flange thickness RF	38.2	44.5	54	62	70	73
D	Total flange thickness RJ	39.7	46	55.7	63.6	71.4	74.4
E	CL to top of stem	210	232				
F	CL to bottom of body/cap	148	165	202	263	313	386.5
G	Hand wheel diameter			600	700	775	700
H1	Body width from CL	85	93	125	155	184	205
H2	Body width from CL	100	112				
J	Stem across flats	25.3	25.3				
K	Depth of flats with stop plate	26	26				
K	Depth of flats without stop plate	34	34				
L	Stem diameter	35	35				
O	Raised face diameter RF	127	157	216	270	324	381
O	Raised face diameter RJ	146	175	241	302	356	413
R	CL to face of hand wheel			383	421	520.5	514
S	CL valve to CL operating spindle			150	150	63	25
T	CL to top of hand wheel			702	774	834	836
U	CL to end of fitted wrench	922	922				
	Weight (approx) kg	41(BW) 52(FL)	62(BW) 80(FL)	168(BW) 200(FL)	330(BW) 457(FL)	540(BW) 650(FL)	740(BW) 810(FL)
	Wrench Number	B5S	B5L	-	-	-	-

HRL633
Flanged Class 600RF
80 & 100mm (3 & 4")

HRL655
Flanged Class 600RJ
80 & 100mm (3 & 4")

HRL666
Butt Weld End
80 & 100mm (3 & 4")

HRG633
Flanged Class 600RF
150-300mm (6-12")

HRG655
Flanged Class 600RJ
150-300mm (6-12")

CLASS 600 VENTURI PATTERN

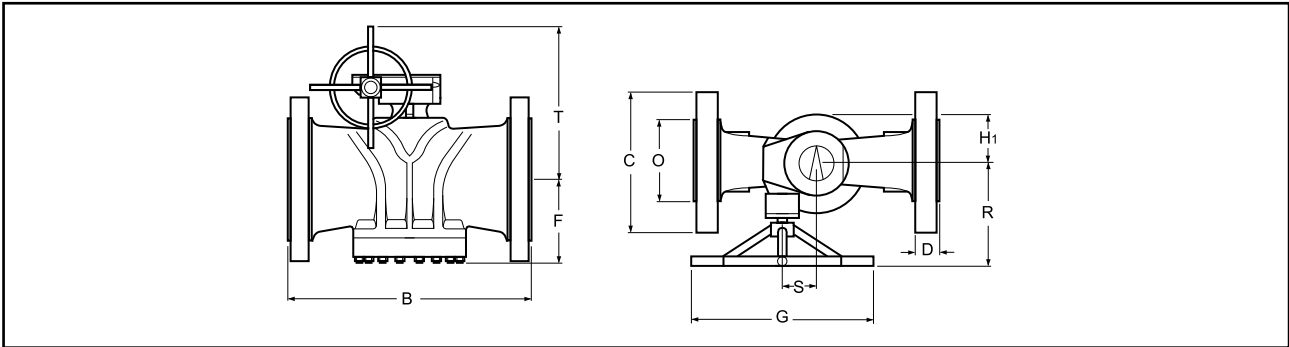

		150 (6")	200 (8")	250 (10")	300 (12")
B	End-to-end butt weld valves	559	660	787	838
B	face-to-face RF	559	660	787	838
B	Face-to-face RJ	562	664	791	841
C	Flange diameter	356	419	508	559
D	Total flange thickness RF	54.2	62	70	73
D	Total flange thickness RJ	55.7	63.5	71.5	74.5
F	CL to bottom of body/cap	178	203	261	340
G	Hand wheel diameter	600	60	600	650
H1	Body width from CL	96	150	159	195
O	Raised face diameter RF	216	270	324	381
O	Raised face diameter RJ	241	301.8	356	413
R	CL to face of hand wheel	350	382	382	583
S	CL valve to CL operating spindle	105	148	148	58
T	CL to top of hand wheel	546	685	700	792
	Weight (approx) kg	127(BW) 160(FL)	180(BW) 244(FL)	452 (FL)	455(BW) 633(FL)

HVG633
Flanged Class 600RF
150-300mm (6-12")

HVG655
Flanged Class 600RJ
150-300mm (6-12")

HVG666
Butt Weld End
150-300mm (6-12")

CLASS 600 VENTURI PATTERN

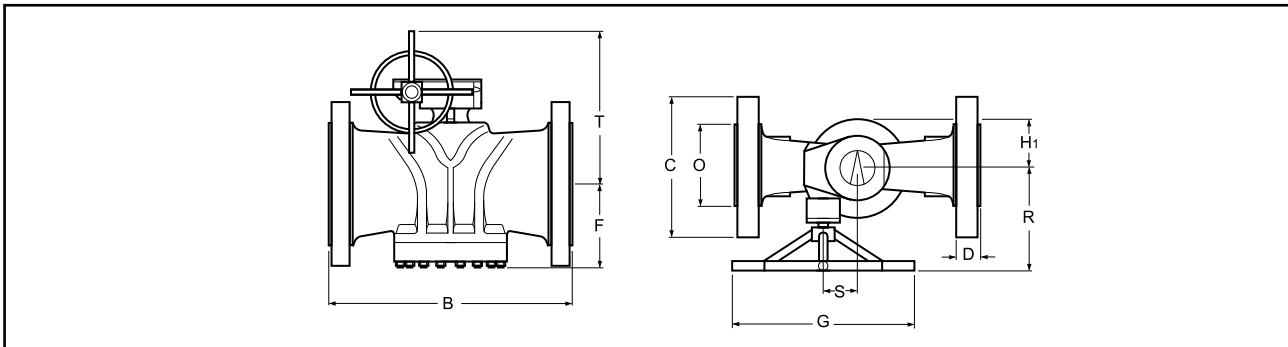

		350 (14")	400 (16")	450 (18")	500 (20")	600 (24")	650 (26")	750 (30")	900 (36")
B	End-to-end butt weld valves	889	990.6	1092	1194	1397	1448	1651	2083
B	face-to-face RF	889	990.6	1092	1194	1397	1448	1651	2083
B	Face-to-face RJ	892	994	1095	1200	1407	1461	1664	2099
C	Flange diameter	603	686	743	813	940	1016	1130	1315
D	Total flange thickness RF	76.5	82.6	89	95.4	108	114.4	120.7	131.4
D	Total flange thickness RJ	78	84.2	90.5	98.5	112.8	120.8	127	139.3
F	CL to bottom of body/cap	388	417	451	485	512	689	689	858
G	Hand wheel diameter	650	700	700	800	800	800	800	1000
H1	Body width from CL	207	221	305	325	365	460	506	700
O	Raised face diameter RF	413	470	533.4	584.2	692.2	749.3	857.3	1022.3
O	Raised face diameter RJ	457.2	508	574.5	635	749.3	810	917.5	1092.2
R	CL to face of hand wheel	583	512	630	610	610	610	610	820
S	CL valve to CL operating spindle	57.5	25.5	215	230	230	230	230	340
T	CL to top of hand wheel	817	877	915	1076	1114	1304	1304	1584
	Weight (approx) kg	880	1260	1673	2380	3140	4900	6350	9720

HVG633
Flanged Class 600RF
350-900mm (14-36")

HVG655
Flanged Class 600RJ
350-900mm (14-36")

HVG666
Butt Weld End
350-900mm (14-36")

CLASS 800 REGULAR PATTERN

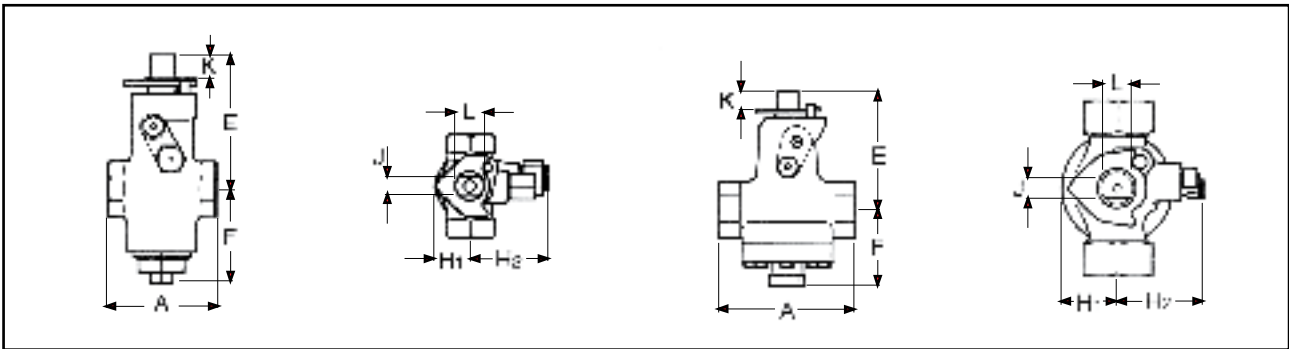

		15 (1/2")	20 (3/4")	25 (1")	40 (1 1/2")	50 (2")
A	End-to-end Screwed / SWE	89	133	133	229	229
E	CL to bottom of stem / injector	121	141	141	191	191
f	CL to bottom of body/ cap	76	97	97	126	126
H1	Body width from CL	31	41.5	41.5	63	63
H2	Body width from CL	73	76	76	106	106
J	stem across flats	13	17	17	25.3	25.3
K	Depth of flats with stop plate	18	24	24	26	26
K	Depth of flats without stop plate	25	30	30	35	35
L	Stem diameter	19	22.2	22.2	35	35
U	CL to end of fitted wrench	231	318	318	685	685
Z	ID socket	21.7	27.5	34.1	49	61.2
ZA	Depth of socket	10	13	13	13	16
	Weight (approx) kg	2.5	6.8	6.8	22	24.5
	Wrench number	B8	B9	B9	B5S	B5S

HRL822
Screwed BSP Tpr
15-50mm (1/2-2")

HRL844
Screwed API
15-50mm (1/2-2")

HRL899
Socket Weld End
15-50mm (1/2-2")

CLASS 900 REGULAR PATTERN

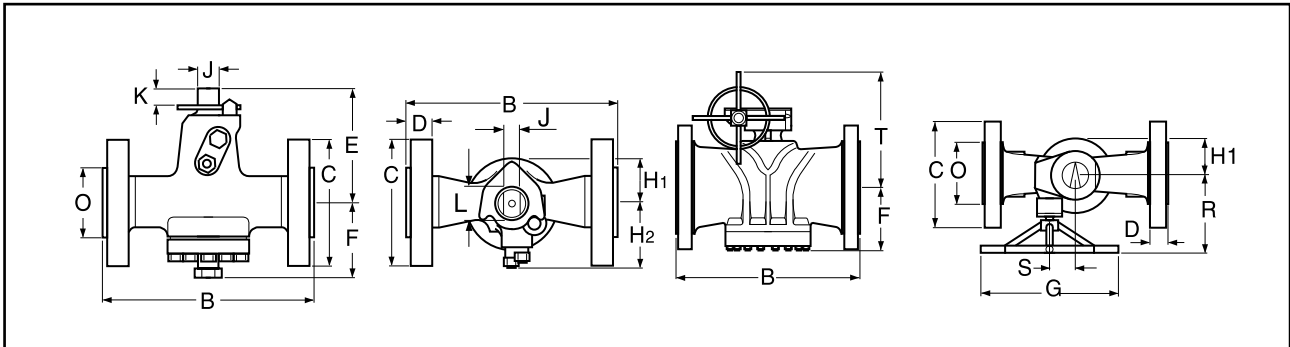

		15-50 (1/2"-2")	80 (3")	100 (4")	150 (6")	200 (8")	250 (10")	300 (12")
B	Face-to-face RF	Screwed end valve dimensions are same as Class 800 Regular pattern Flanged valve dimensions are same as Class 1500 Regular pattern	381	457	610	737	838	965
B	Face-to-face RJ		384	460	613	740	841	968
C	Flange diameter		242	293	381	470	546	610
D	Total flange thickness RF		44.5	50.9	62	69.9	76.4	85.7
D	Total flange thickness RJ		46	52.4	63.5	71.4	77.9	87.2
E	CL to top of stem		234	232	--	--	--	--
F	CL to bottom of body/cap		163	182.3	231.7	284.3	283.2	354
G	Hand wheel diameter		--	600	700	700	700	700
H1	Body width from CL		89	99	130	317	179	220
H2	Body width from CL		130.7	144.2	--	279	--	--
J	Stem across flats		28.5	--	--	--	--	--
K	Depth of flats with stop plate		34	34	--	--	--	--
K	Depth of flats without stop plate		42	42	--	--	--	--
L	Stem diameter		41	41	--	--	--	--
O	Raised face diameter RF		127	157.3	215.9	269.7	323.85	381
O	Raised face diameter RJ		155	181	241	308	362	419
R	CL to face of hand wheel		--	429	422	422	437	557
S	CL valve to CL operating spindle		--	104.8	148	147.86	227	138
T	CL to top of hand wheel		--	720	256	775	766	766
U	CL to end of fitted wrench		933	913	--	--	--	--
	Weight (approx) kg	78	125	274	470	860	1075	
	Wrench number	B7	B7	--	--	--	--	

HRL922
Screwed BSP Tpr
15-50mm (1/2-2")

HRL933
Flanged Class 900RF
80 & 100mm (3 & 4")

HRL944
Screwed API
15-50mm (1/2-2")

HRL955
Flanged Class 900RJ
80-100mm (3 & 4")

HRL999
Socket Weld End
15-50mm (1/2-2")

HRG933
Flanged Class 900RF
150-300mm (6-12")

HRG955
Flanged Class 900RJ
150-300mm (6-12")

CLASS 900 VENTURI PATTERN

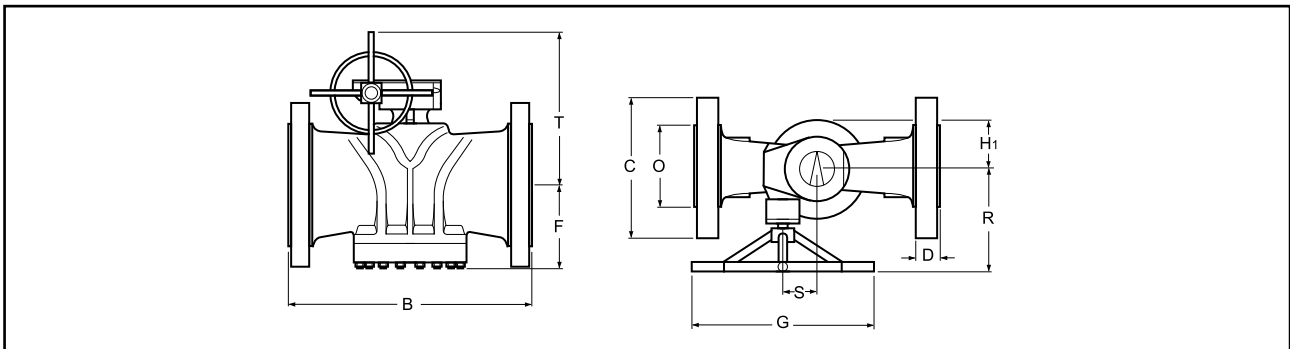

		300 (12")	350 (14")	400 (16")	450 (18")	500 (20")	600 (24")
B	Face-to-face RF	965	1029	1130	1219	1321	1549
B	Face-to-face RJ	968.4	1038.6	1140	1231.8	1333.5	1568.5
C	Flange diameter	610	641.4	705	787.4	857.25	1042
D	Total flange thickness RF	85.7	92.3	95.3	108	114.3	146.1
D	Total flange thickness RJ	87.22	97	100.02	114.3	120.65	155.6
F	CL to bottom of body/cap	354	486	491	522	556	663
G	Hand Wheel diameter	700	700	700	800	800	900
H1	Body width from CL	220	273	273	243	397	450
O	Raised face diameter RF	381	412.8	469.9	534	584.2	692.5
O	Raised face diameter RJ	419	466.9	524	594	647.7	771.7
R	CL to Face of handwheel	557	629.5	629.5	579	579	629
S	CL Valve to CL Operating Spindle	138	215	215	230	230	280.5
T	CL Valve to Top of Hand wheel	766	1003	1037.5	1178	1181.7	1304
	Weight (approx) kg	1075	1130	2050	2350	3400	5450

HVG933
Flanged Class 900RF
300-600mm (12-24")

HVG955
Flanged Class 900RJ
300-600mm (12-24")

CLASS 1500 REGULAR PATTERN

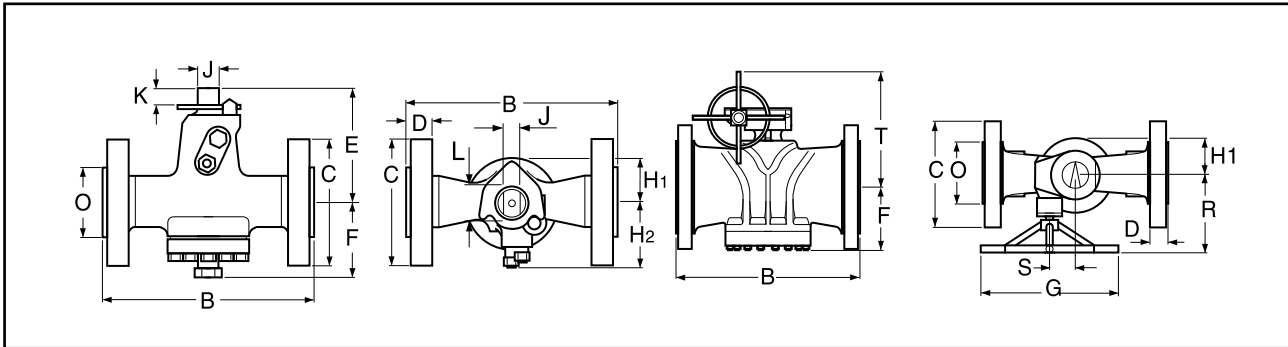

	15 (1/2")	20 (3/4")	25 (1")	40 (1.1/2")	50 (2")	80 (3")	100 (4")	150 (6")	
B	Face-to-face RF	216	229	254	305	368	470	546	705
B	Face-to-face RJ	216	229	254	305	371	473	549	711
C	Flange diameter	121	130	149.5	178	216	267	311.5	394
D	Total flange thickness RF	28.8	31.8	34.9	38.2	44.5	54.2	60.2	88.9
D	Total flange thickness RJ	28.75	31.8	34.9	38.2	46	55.72	61.75	92
E	CL to top of stem	119	141	180	296	302	322	442	565
F	CL to bottom of body/cap	80	97	97	151	151	182	229	288
G	Hand Wheel diameter	--	--	--	600	600	600	600	600
H1	Body width from CL	29	41.5	44.5	105	105	114	111	152
H2	Body width from CL	44	52	52	105	105	114	111	152
J	Stem across flats	13	17	17	28.5	--	--	--	--
K	Depth of flats with stop plate	17.6	22.6	22.6	34	--	--	--	--
K	Depth of flats without stop plate	25	30	30	42	--	--	--	--
L	Stem diameter	19	22.2	22.2	41/45	45	45	45	70
O	Raised face diameter RF	35	42.9	50.8	73.2	92	127	157.3	215.9
O	Raised face diameter RJ	60.5	66.6	71.4	91.9	123.9	168.2	193.6	247.7
R	CL to Face of handwheel	--	--	--	340	340	340	422	593
S	CL Valve to CL Operating Spindle	--	--	--	86	86	86	148	58
T	CL Valve to Top of Hand wheel	--	--	--	528	528	554	588	627
U	CL to end of fitted wrench	230	318	318	--	--	--	--	--
	Weight (approx) kg	4.5	8.5	13.5	40/60	85	140	170	Refer to SAV
	Wrench number	B8	B9	B9	B7	--	--	--	--

HRLA22
Screwed BSP Tpr *
15-50mm (1/2-2")

HRLA33
Flanged Class 1500RF
15-80mm (1/2-3")

HRLA44
Screwed API *
15-50mm (1/2-2")

HRGA33
Flanged Class 1500RF
100 & 150mm (4 & 6")

HRLA55
Flanged Class 1500RJ
15-80mm (1/2-3")

HRLA66
Butt Weld End
50mm (2")

HRLA99
Socket Weld End *
15-50mm (1/2-2")

HRLA55
Flanged Class 1500RJ
100 & 150mm (4 & 6")

* For dimensions of screwed and socket weld end valves 15-50mm see Class 800 Regular Pattern

CLASS 1500 VENTURI PATTERN

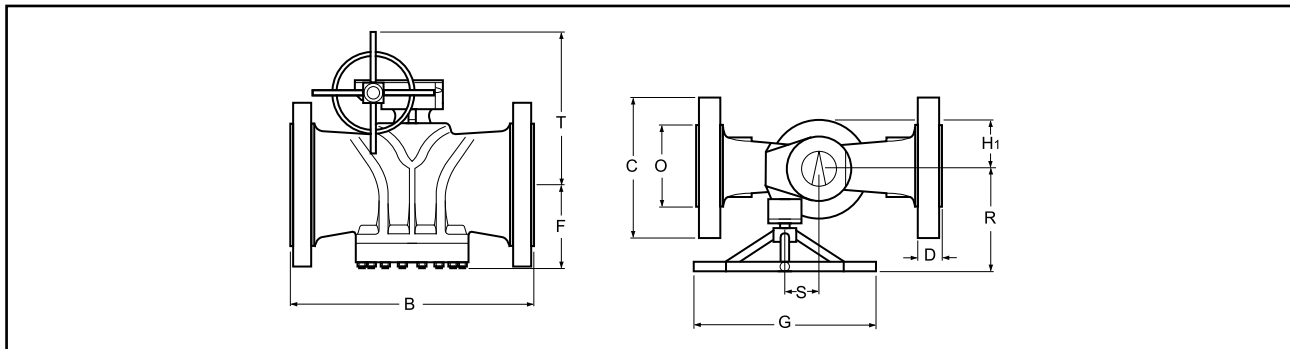

		150 (6")	200 (8")	250 (10")	300 (12")	350 (14")	400 (16")	450 (18")	500 (20")	600 (24")
B	Face-to-face RF	705	832	991	1130	1257	1384	1537	1664	1944
B	Face-to-face RJ	711	841.4	1000	1146.2	1276.4	1406.2	1559	1686	1972
C	Flange diameter	394	483	584.2	673.1	750	826	915	985	1169
D	Total flange thickness RF	88.9	98.4	114.4	130.4	139.8	152.5	168.4	184.2	216
D	Total flange thickness RJ	92	103.1	119.13	138.3	149.3	163.6	179.5	195.3	223.8
F	CL to bottom of body/cap	253.5	337	393	394	394	552	608	797	737
G	Handwheel diameter	700	700	700	700	700	800	800	800	800
H1	Body width from CL	130	194	260	280	280	395	438	488	488
O	Raised face diameter RF	216	270	324	381	413	470	533	584	692
O	Raised face diameter RJ	247.7	317.5	371.4	438.2	489	546.1	612.7	673	794
R	CL to face of handwheel	421	536	619	619	619	609	609	703	703
S	CL valve to CL operating spindle	149	50.7	215	215	215	230	230	230	230
T	CL to top of handwheel	746.5	846	1026.5	1108.6	1173.7	1406.1	1495.5	1051	1121
	Weight (approx) kg	365	790	1420	1850	2610	3250	Refer to SAV	Refer to SAV	Refer to SAV

HVGA33
Flanged Class 1500RF
150-600mm (6-24")

HVGA55
Flanged Class 1500RJ
150-600mm (6-24")

HVGA66
Butt Weld End
150-600mm (6-24")

CLASS 2500 REGULAR PATTERN

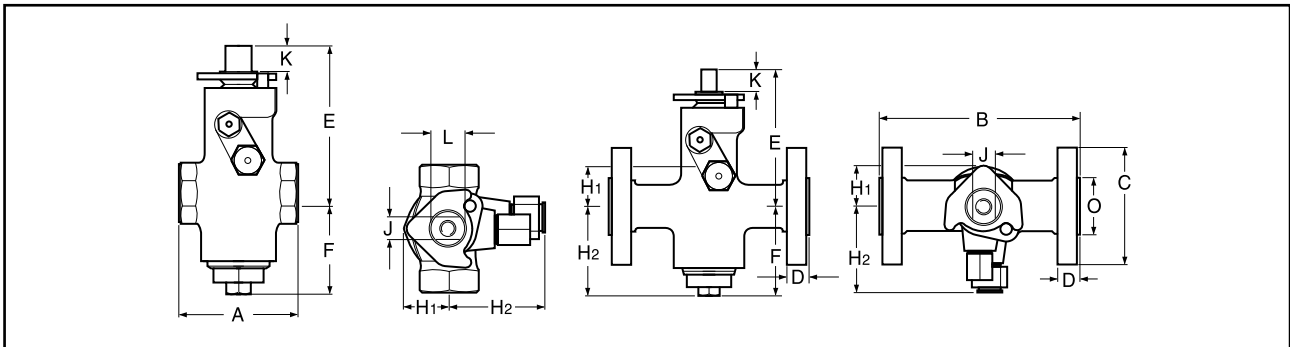

	15	20	25	40	
A	End-to-end screwed valves	89	133	133	--
B	Face-to-face RF	264	273	308	384
B	Face-to-face RJ	264	273	308	387
C	Flange diameter	133.5	139.7	160	203.5
D	Total flange thickness RF	36.6	38.2	41.4	50.9
D	Total flange thickness RJ	36.6	38.2	41.4	52.4
E	CL to top of stem	120	141	141	--
F	CL to bottom of body/cap	76.5	97	97	189
H1	Body width from CL	34	46.5	46.5	--
H2	Body width from CL	69.3	76.8	76.8	--
J	Stem across flats	13	17	17	--
K	Depth of flats with stop plate	19	24	24	--
K	Depth of flats without stop plate	25	30	30	--
L	Stem diameter	19	22.2	22.2	--
O	Raised face diameter RF	35	42.9	50.8	73.2
O	Raised face diameter RJ	65	73.2	82.6	114.3
U	CL to end of fitted wrench	230	318	318	685
	Weight	2.5/13	6.8/18	17/22	47/73
	Wrench number	B8	B9	B9	B5S

HRLB22
Screwed BSP Trp
15-25mm (½-1")

HRLB33
Flanged Class 2500RF
15-40mm (½-3/4")

HRLB44
Screwed API
15-25mm (½-1")

HRLB55
Flanged Class 2500RJ
15-40mm (½-3/4")

HRLB99
Socket Weld End
15-25mm (½-1")

50mm & ABOVE ARE GEAR OPERATED

CLASS 2500 REGULAR PATTERN

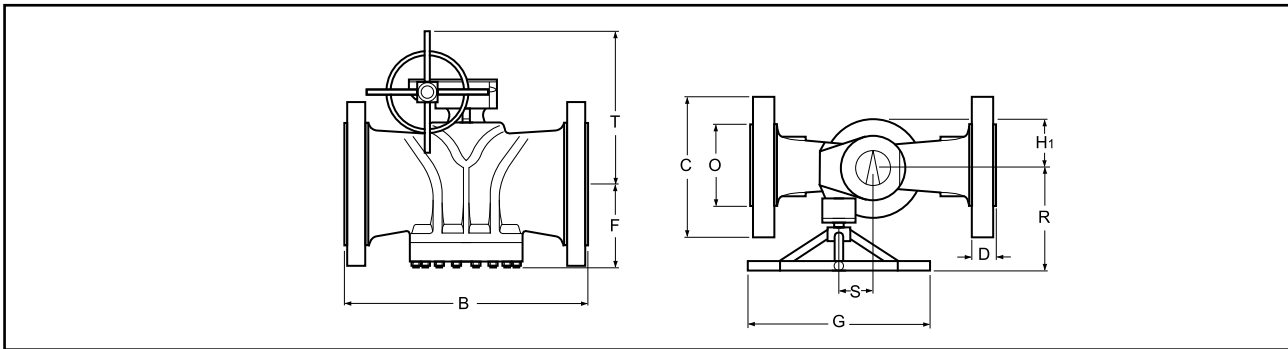

		50	80	100	150	200	250	300	350-600
B	Face-to-face RF	451	578	673	914	1022	1270	1422	The dimensions for these sizes are not defined by standards and will be agreed with customer on request.
B	Face-to-face RJ	454	584	683	927	1038	1292.2	1445	
C	Flange diameter	235	305	356	482.6	553	673.1	762	
D	Total flange thickness RF	57.2	72.9	82.6	114.4	133.4	171.5	190.6	
D	Total flange thickness RJ	58.7	76.02	87.3	120.7	141.3	182.6	201.7	
F	CL to bottom of body/cap	189	251.4	240.7	322	387	387	530	
G	Hand wheel diameter	600	600	600	800	700	700	700	
H1	Body width from CL	115	145	143	178	225	225	280	
O	Raised face diameter RF	92	127	157.2	215.9	269.8	323.85	381	
O	Raised face diameter RJ	133.3	168.3	203.2	279.4	339.9	425.45	495.3	
R	CL to face of handwheel	350	352	352	530	639	639	Refer to SAV	
S	CL valve to CL operating spindle	105	148	148	138	215	215		
T	CL to top of handwheel	531	576	634	705	900	900		
	Weight (approx) kg	131	240	665	740	1150	1800		

HRGB33
Flanged Class 2500RF
50-300mm (2-12")

HRGB55
Flanged Class 2500RJ
50-300mm (2-12")

HRGB66
Butt Weld End
50mm (2")

API 2000 & 3000

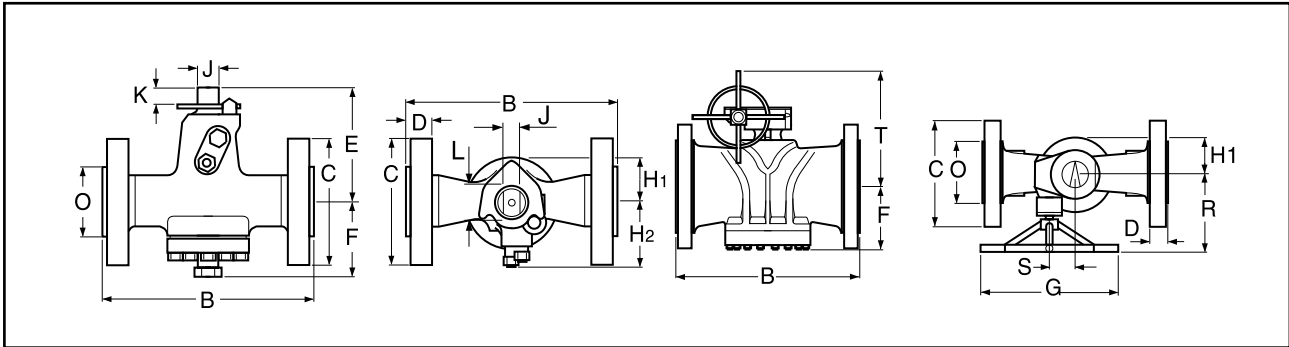

HRLC55
Flanged Class API 2000RJ
78-103mm (3 1/8 - 4 1/16")

HRGC55
Flanged Class API 2000RJ
103mm (4 1/16")

HRLD55
Flanged Class API 3000RJ
52-103mm (2 1/16 - 4 1/16")

HRGD55
Flanged Class API 3000RJ
103mm (4 1/16")

		API 2000			API 3000			
		78 (3"1/8")	103 (4"1/16") (Lever)	103 (4"1/16") (Gear)	52 (2"1/16")	78 (3"1/8")	103 (4"1/16") (Lever)	103 (4"1/16") (Gear)
B	Face-to-face RJ	359	435	435	372	384	460	460
C	Flange diameter	210	273	273	216	241	295	295
D	Total flange thickness RF	39.7	46	46	46	46	52.4	52.4
E	CL to top of stem	232	237	237	190	232	282	282
F	CL to bottom of body/cap	167	203	203	132	180	203	203
G	Hand wheel diameter	-	-	600	-	-	-	600
H1	Body width from CL	89	107	107	73	101	107	107
H2	Body width from CL	100	112	112	89	100	112	112
J	Stem across flats	28.5	32.4	-	25.3	28.5	32.4	-
K	Depth of flats with stop plate	35	36	-	26	34	34	-
K	Depth of flats without stop plate	42	42	-	34	42	42	-
L	Stem diameter	41	41	-	35	41	41	-
O	Raised face diameter RJ	146	175	175	124	156	181	181
R	CL to face of handwheel	-	-	365	-	-	-	351
S	CL Valve to CL Operating Spindle	-	-	128	-	-	-	105
T	CL Valve to Top of Hand wheel	-	-	545	-	-	-	545
U	CL to end of fitted wrench	933	933	-	684	933	933	-
	Weight (approx) kg	46	85	110	38	85	125	150
	Wrench number	B7	B7S	-	B5S	B7	B7S	-

API 5000 & 10000

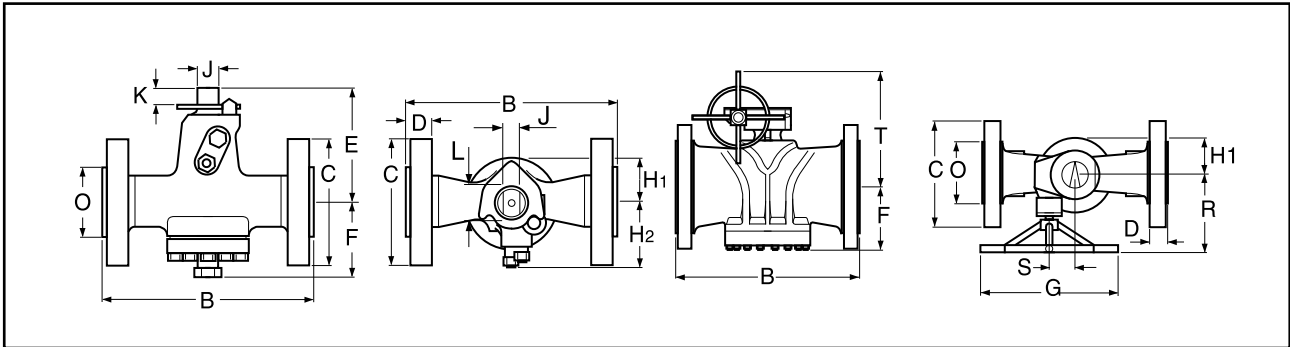

HRLE55
Flanged Class API 5000RJ
78-103mm (3 1/8 - 4 1/16")

HRGE55
Flanged Class API 5000RJ
103mm (4 1/16")

HRGF55
Flanged Class API 10000RJ
46-103mm (1 13/16 - 4 1/16")

		API 5000			API 10000			
		78 (3"1/8")	103 (4"1/16") (Lever)	103 (4"1/16") (Gear)	46 (1"13/16")	52 (2"1/16")	78 (3"1/16")	103 (4"1/16")
B	Face-to-face RJ	473	549	549	464	521	619	670
C	Flange diameter	267	311	311	185	200	270	315
D	Total flange thickness RF	55.6	61.9	61.9	42.1	44.1	58.4	70.3
E	CL to top of stem	232	228	-	-	-	-	-
F	CL to bottom of body/cap	180	235	235	277	277	312	342
G	Hand wheel diameter	-	-	600	600	600	600	700
H1	Body width from CL	101	123	123	138	138	160	203
H2	Body width from CL	100	112	112	154	154	190	224
J	Stem across flats	28.5	32.4	-	-	-	-	-
K	Depth of flats with stop plate	34	34	-	-	-	-	-
K	Depth of flats without stop plate	42	42	-	-	-	-	-
L	Stem diameter	41	41	-	-	-	-	-
O	Raised face diameter RJ	168	194	194	105	111	152	185
R	CL to face of handwheel	-	-	365	480	480	510	545
S	CL Valve to CL Operating Spindle	-	-	128	63	63	28.5	51
T	CL Valve to Top of Hand wheel	-	-	558	605	605	677	752
U	CL to end of fitted wrench	933	933	-	-	-	-	-
	Weight (approx) kg	86	130	170	240	252	370	630
	Wrench number	B7	B7S	-	-	-	-	-

Sealants

Serck Audco Super-H valves are designed in a way that no spares will be required, the only minimal maintenance can be quickly done in-line and with the valve under pressure through sealant injection. Also, in comparison to other plug valve designs, the Super-H can guarantee zero leakage seal and smooth operation with minimal sealant injection frequency.

Serck Audco Sealants are high viscosity fluids, specially produced to seal and lubricate plug valves. Only Serck Audco sealants should be used in Serck Audco valves unless authorised by us. The use of a sealant or commercial greases not recommended by us can impair the functioning of the valve and in the worst case seize it completely.

Sealant is injected into the Super-H to ensure valve tight shut-off and maintain low torque. Audco sealants have excellent lubricating properties and great film strength. They supplement Super LoMu treatment to reduce friction between the seating surfaces and provide a very effective seal, even at higher line pressures.

Sealants should be selected based on service media and operating temperature. The tables below summarise our general sealant recommendations. Sealant should be carefully selected since the use of the correct Serck Audco Sealant will minimize injection frequency. The tables are self explanatory, however, if in doubt regarding sealant selection, Serck Audco can suggest a suitable sealant against service details.

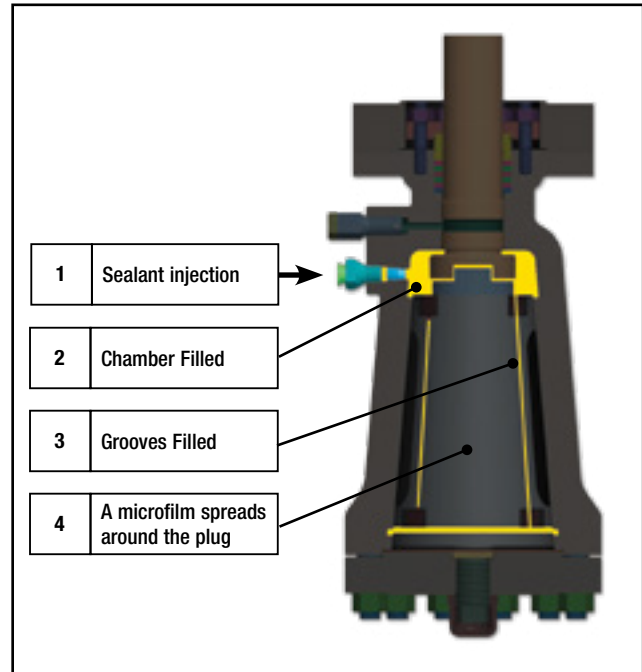

Multi-Purpose Sealants

Serck Audco Valves research pays careful attention to the development of multi-purpose sealants to simplify plant maintenance where many services are encountered. As a result, we are able to offer three sealants which cover a very wide variety of services and have replaced many of the older Serck Audco sealants. A single multi-purpose Serck Audco sealant can often be used throughout an entire plant, often handling a variety of fluids. This simplifies maintenance and reduces the number of sealants which need to be kept.

Sealant	Form	Colour	Temp Range °C (°F)		Recommended for	Do not use on
			Min	Max		
733	K Sticks Cartridges Bulk	Cream	-20 (-5)	250 (480)	Most Hydrocarbon services, Butane, propane, gasoline, kerosene, oils, fuel oils, most hydrocarbon solvents. Sweet and sour natural and manufactured gas with water organic condensates, LPG systems, glycols	Strong alkali and high aromatic and chlorinated solvents
735	K Sticks Hard grade Bulk only	Black	-40 (-40)	325 (620)	Premium Multipurpose Sealant suitable for a range of fluids including hydrocarbon, water, amines and methanol Suitable for high / low temperature applications	Neat petroleum products Strong mineral acids Chlorinated and aromatic acids
731	K Sticks Cartridges Bulk	Cream	-15 (0) -20 (-5) -25 (-13)	230 (450) 230 (450) 230 (450)	Most chemical plant services, compressed air, water, aqueous solutions, dilute acids, all alkaline solutions tars and bitumens	Strong acid solutions, hydrocarbons, chlorinated and aromatic solvents

Specialised Sealants

Even though our multipurpose sealants can cover most applications, we can still supply our range of specialised sealants for those customers that prefer to use them.

Sealant	Form	Colour	Temp Range °C (°F)		Recommended for	Do not use on
			Min	Max		
985	K Sticks Cartridges Soft grade Bulk only	Light Brown	-10 (12)	150 (300)	Sweet and sour natural and manufactured gas with water/organic condensates Preferred at elevated temperatures	As 733
201	K Sticks Cartridges Bulk	White	-7 (-20)	200 (390)	Domestic water services, foodstuffs and pharmaceuticals	As 731
147	K Sticks Cartridges Bulk	White	-10 (14)	70 (160)	Nitrating acids, sulphuric acid and other oxidising elements	Hydrocarbon chlorinated and aromatic solvents
563	K Sticks Cartridges Bulk	Yellow	-10 (14)	150 (300)	Chlorinated and aromatic hydrocarbon solvents	Strong acids, nitrating acids, water and water based services and alcohols
734	K Sticks Cartridges Bulk	Cream	0 (32)	170 (340)	Water, high pressure, hot water and steam	As 731
591	K Sticks Cartridges Bulk	Cream	0 (32)	300 (570)	Petroleum based heat transfer oils. Hot fuel oil to 120°C	As 733
608	K Sticks Cartridges Bulk	Off White	0 (32)	340 (650)	Hot hydrocarbon gases and vapours including high temperature cracking and reforming Strong acids and alkalis to 150°C	Aromatic and chlorinated solvents Liquid hydrocarbons and nitrating acids
733LT	K Sticks Cartridges Bulk	Brown	-30 (-20) -46 (-50)	150 (300) 100 (200)	As for 733, but particularly useful at lower temperatures and winter conditions	As for 733
574	Cartridges Soft grade Bulk only	Beige	-50 (-58)	50 (120)	Ammonia and brine	As 731
2977	K Sticks Cartridges Soft grade Bulk only	Black	-40 (-40)	325 (620)	As for 735, also oil and water mixtures where water content is above 50% in the mixture	As 735

Sealant Injection Equipment

To ensure sealant injection is a quick and easy operation, all Super-H pressure balanced plug valves are fitted with giant button head sealant injector positioned as a side feed in the body. All injection equipment is fitted with flexible hoses giving a hook-on connection to the sealant injector on the valve, enabling a safe set up for the injection operation in just few seconds.

The sealant injection equipment is specialized high pressure equipment and no other injection tools shall be used unless with our express recommendation

400-D Sealant Gun

Hand operated hydraulic gun, fitted with a pressure gauge. Suitable for small number of valves or valves in remote locations, this gun is designed to take Size 'K' sealant sticks.

Effortless to operate, the 400D gives positive indication of when a valve has been fully charged.

The 400D replaces the now obsolete ALG4 gun. Cartridges for use with ALG4 gun are still available

10-90 Pneumatic Pump

Trolley mounted, pneumatically operated large capacity injector pump. Suitable for large numbers or sizes of valves, the pump is designed to take five Quarter sealant cans. The pump will run when connected to an air supply that could be a compressed air system or an air bottle.



Sealants Packaging

Sealant is packed in different forms to enable its use with the different available injection equipment.

Sealants Packaging	K Sticks – Box of 12	Cartridges – Box of 12	5 Quarter Can
For Use on	400D Sealant Gun	ALG4 Gun (superseded)	10-90 Pneumatic Pump
Stick Size (mm)	35ø x 240	50ø x 220	192ø x 203
Box Size (mm)	150 x 180 x 280	165 x 205 x 245	n/a
Box Weight (Kg)	4	5.2	5

*Weights will vary from those shown over a range of approximately 20-30% according to grade of sealant.
Sealant can also be purchased in bulk large containers of 18Kg, 80Kg and 180 Kg*

Serck Audco Stem Packing Compound

Serck Audco Stem Packing Compound is a special graphite based material prepared in stick form for easily sealing the stems of our Super-H valves. At any time and even with the valve under full pressure the stem packing can be re-injected to restore original stem tightness.

Stem packing is not sealant and must under no circumstances be used in the valve sealant system. Also, valve sealants are not suitable for sealing stems. Stem packing compound is supplied packed in boxes as follows:

Stick Size	A	B	D
Suitable for valves in sizes	½" – 1"	1 ½" – 2"	≥3"
Number of Sticks per Container	40	24	24
Box Size (mm)	70ø x 60	70ø x 60	70ø x 150
Box Weight (Gr)	100	100	330

The Products of Success

Super-H Pressure Balanced Plug Valve



A high pressure plug valve, achieving exceptional reliability on both leak tightness and operability. The valve ensures long-term line and atmospheric sealing, minimizes routine maintenance, and is fire tested to API6FA.

Materials: Carbon Steel, Alloy Steel, Duplex Stainless Steel and Special Materials
Sizes: 15 to 1050mm
Pressures: Up to 690 bars (10000 psi) Maximum Cold Working Pressure
Temperatures: -46°C to +325°C
Ratings: ANSI 150-2500, API 2000, 3000, 5000 and 10000

Double Isolation Plug Valve (DIPV)



DIPV gives all the advantages of our pressure balanced plug valve but also provides a double block and bleed system with true double isolation and two independent obturators in an extremely compact form. In the DIPV, the plugs are mounted in inverse orientation to obtain the maximum port area

Materials: Carbon Steel, Alloy Steel, Duplex Stainless Steel and Special Materials
Sizes: 15 to 600mm
Pressures: Up to 690 bars (10000 psi) Maximum Cold Working Pressure
Temperatures: -46°C to +325°C
Ratings: ANSI 150-2500, API 2000, 3000, 5000 and 10000

Twin Isolation Plug Valve (TIPV)



TIPV gives all the advantages of our pressure balanced plug valve but also provides a double block and bleed system with true double isolation and two independent obturators in an extremely compact form. In the TIPV, the plugs are mounted in same orientation to facilitate installation on particular plant layouts

Materials: Carbon Steel, Alloy Steel, Duplex Stainless Steel and Special Materials
Sizes: 15 to 600mm
Pressures: Up to 690 bars (10000 psi) Maximum Cold Working Pressure
Temperatures: -46°C to +325°C
Ratings: ANSI 150-2500, API 2000, 3000, 5000 and 10000

Full Bore Plug Valve (FBPV)



Based on the Super-H valve design, the FBPV is designed for extremely abrasive applications where valves are required to be piggable, and turbulence or obstruction to the flow path is not allowed.

Materials: Carbon Steel, Alloy Steel, Duplex Stainless Steel and Special Materials
Sizes: 15 to 600mm
Pressures: Up to 690 bars (10000 psi) Maximum Cold Working Pressure
Temperatures: -46°C to +325°C
Ratings: ANSI 150-2500, API 2000, 3000, 5000 and 10000

Steam Jacketed Plug Valve



For all applications where the media needs to be maintained at elevated temperatures and metal to metal seats are required, such as molten sulphur, the SAV steam jacketed plug valve provides the best solution. Also suitable for high pressures, it will be supplied with oversized flanges for full jacket option.

Materials: Carbon Steel and Special Materials if required
Sizes: 50x25x50 to 300x250x300mm (higher sizes upon request)
Pressures: Up to 690 bars (10000 psi) Maximum Cold Working Pressure
Temperatures: -46°C to +325°C
Ratings: ANSI 150-2500, API 2000, 3000, 5000 and 10000